

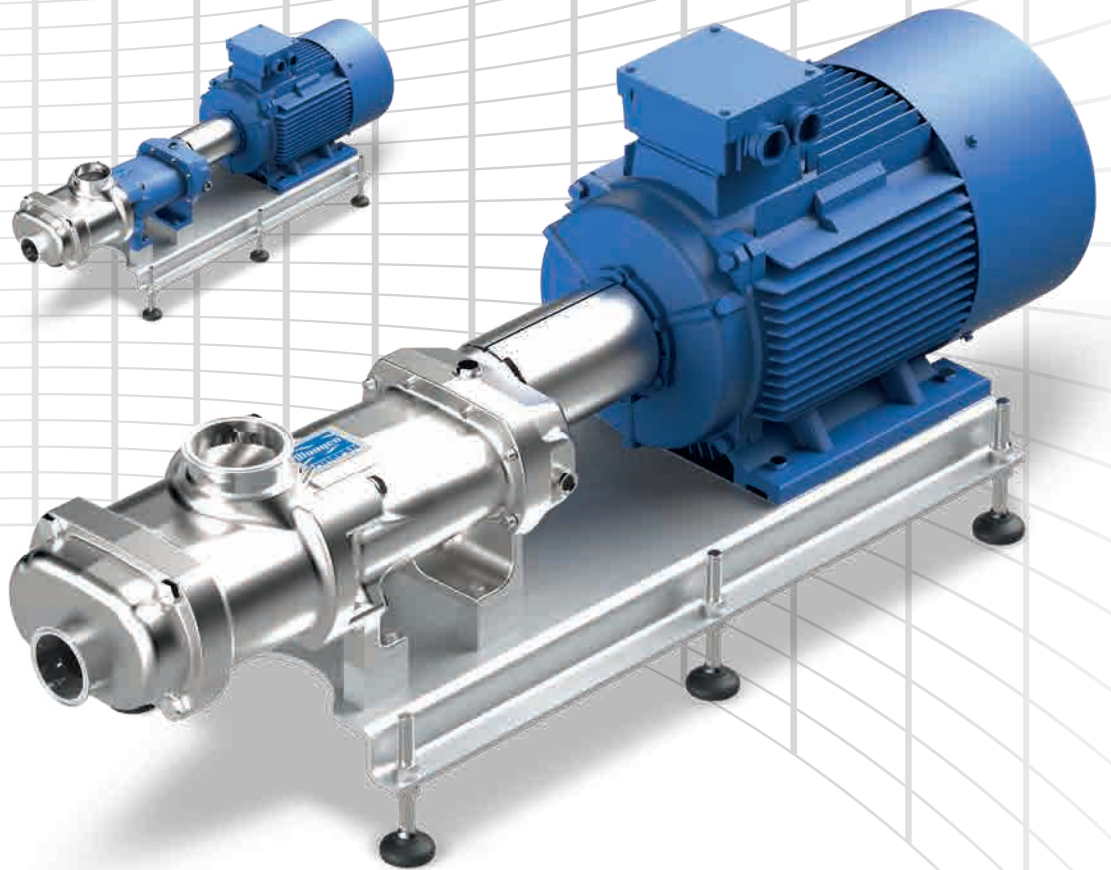

Twin Screw Pump
WANGEN Twin



The hygienic solution for
food, cosmetics and chemicals

Twin screw pump

WANGEN Twin

With the WANGEN Twin, you can avoid time-consuming cleaning, frequent repairs, excessive wear or costly production stoppages. Thanks to the high quality materials and the sophisticated operating principle used, all these details will be a thing of the past. This is why the WANGEN Twin is the most economical solution for your needs.

Especially designed for use in the food and cosmetics industry, WANGEN has clever solutions that meet the strict hygiene regulations in these sectors. One of these solutions is the WANGEN Twin Screw Pump. It is part of the hygienic pumping solutions from WANGEN and was designed to reliably pump low to highly viscous, volatile or gaseous products and for applications where maximum hygiene and efficiency is required. The WANGEN Twin can be optionally heated for conveying special media.

Technical highlights:

Maximum flowrate 100 m³/h

Maximum temperature +130 °C

Max. differential pressure 20 bar

Viscosity up to 1.000.000 mPa·s



Applications

Conveying Materials

The following media can typically be conveyed with the WANGEN Twin Screw Pump in the food, cosmetic and chemical industries:

- Beverages such as direct juice, concentrates, mashes, pulp or yeast
- Dairy products such as yogurt, quark, cheese, pudding or butter
- Ketchup, mayonnaise, mustard, soup, gravy or salad dressings
- Confectionery, such as chocolate, fondant, liquid sugar syrup, sugar, rework or dough
- Fruits like strawberries
- Meat-based products such as minced meat, sausage meat or pet food
- Cosmetic products such as cream, ointment, soap or shampoo
- Chemical products such as raw chemical suspensions, antifreeze liquids, adhesives.



WANGEN Twin pumps in operation



Benefits

Hygienic Excellence

The WANGEN Twin achieves top marks for SIP and CIP cleaning. This is due mainly to the following unique characteristics of the WANGEN Twin used in this combination:

- Very high rotational speed range allows either product or cleaning fluid to be pumped as required
- High rotational speeds in cleaning operations ensure that the self-cleaning effect of the pump works
- High pressure up to 16 bar allows product-filled lines, equipment and fixtures to be emptied using cleaning fluid
- Produced according to the highest hygiene specifications - EHEDG or 3A-certified manufacturing processes

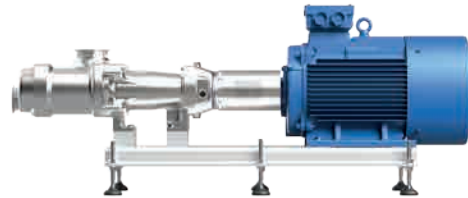

Benefits

Two pumps in one - increased savings, more space

The WANGEN Twin can be used as a product and a CIP pump. After products have been conveyed with the WANGEN Twin, the pump can be filled with water and/or cleaning medium and run at a very high speed so that the pump is cleaned. In this way, cost savings for a separate centrifugal pump, bypass line, valves as well as the measuring and control technology required are achieved.

Using the WANGEN Twin for product transfer and CIP is the optimum solution to overcoming very restricted availability of space in the production area.

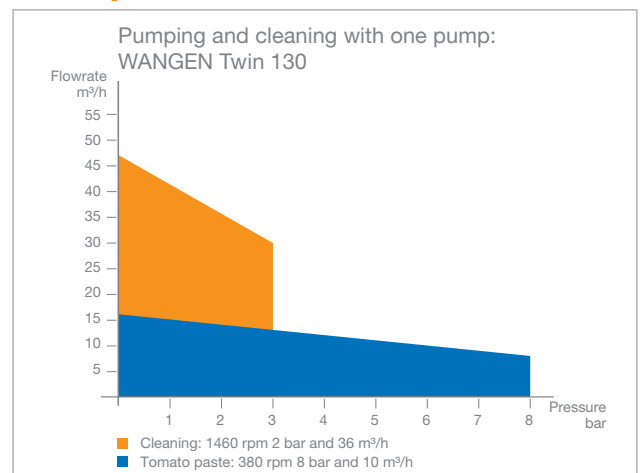

optionally: ■ water
■ product



Conveying and CIP-cleaning with the WANGEN Twin

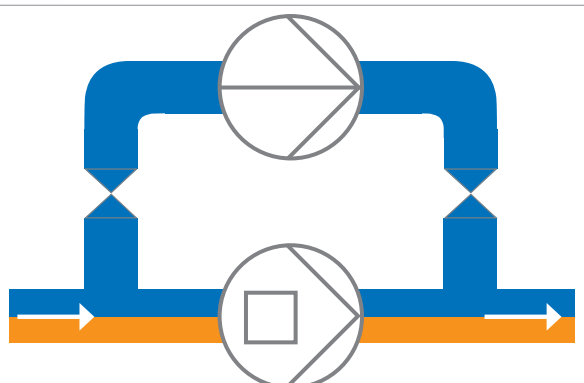

Conveying with displacement pump and CIP-cleaning with centrifugal pump



Benefits

Low Life-Cycle Costs

When buying a pump, we recommend that you consider the operating costs in addition to the initial procurement costs. Maintenance costs and production downtime costs will all make a significant contribution to the overall costs.

A major advantage of our philosophy is clear: To keep the total costs as low as possible throughout the complete life cycle, our approach is to keep service and maintenance to a minimum. This is possible thanks to the robust construction of our pumps, the high quality of the wearing parts and the low-wear design of every pump.

With each production disruption that you avoid, you will save not just the cost of spare parts, but also the costs of maintenance work and production downtimes. This not only saves you money, it also calms your nerves!

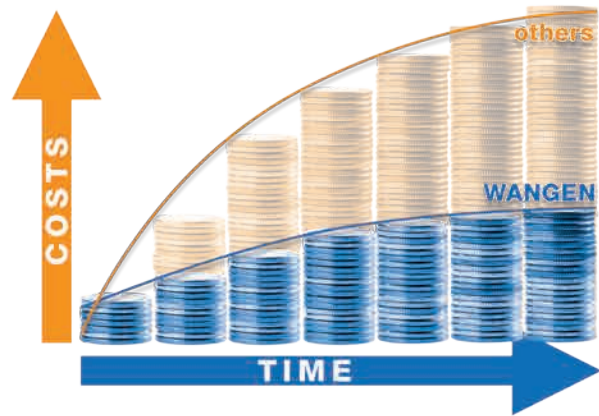

Benefits

Easy Maintenance

In general, WANGEN pumps have a very application and service-friendly design. This makes any maintenance work which is required simpler to carry out by yourself. For example, any wear due to the contact-free operation of the conveyor screws is confined to the bearings, who are designed for long life, and the shaft seal.

The innovative, flexible sealing concept (see page 9) also helps to reduce costs and to increase plant use and availability. There is an economic choice of three possible seals. These can either be procured as a sealing package or separately. In this way, the choice of the seal material and its design has been made in an absolutely cost-optimised way.



Simple manual cleaning

Thanks to the sophisticated design of the WANGEN Twin, manual cleaning is done in no time at all. This is due mainly to the following construction benefits:

- The entire pump casing can be removed by releasing only four screws
- All parts in contact with the product are then freely accessible for cleaning or inspection
- Individual elements and components can be easily separated from one another and connected up again



Technical Data

Design and Materials

In order to ensure the highest operating reliability, WANGEN PUMPEN uses only the best raw materials for the respective purpose. Our many years of experience in the pumping of different media ensures a pump design which does justice to modern quality requirements.

- Materials in contact with product:
Stainless steel 1.4404
- Surfaces in contact with the product:
approx. RA < 0.8 µm
- Ground and electro-polished surfaces (optional)
- Cleaning using CIP (= cleaning in place)
and SIP (= sterilization in place)
- Elastomers conform to FDA and EC1935/2004
requirements
- Constructed and certified according to the
EHEDG and 3A guidelines
- Wide variety of flange connections
- Flexible choice of drive units

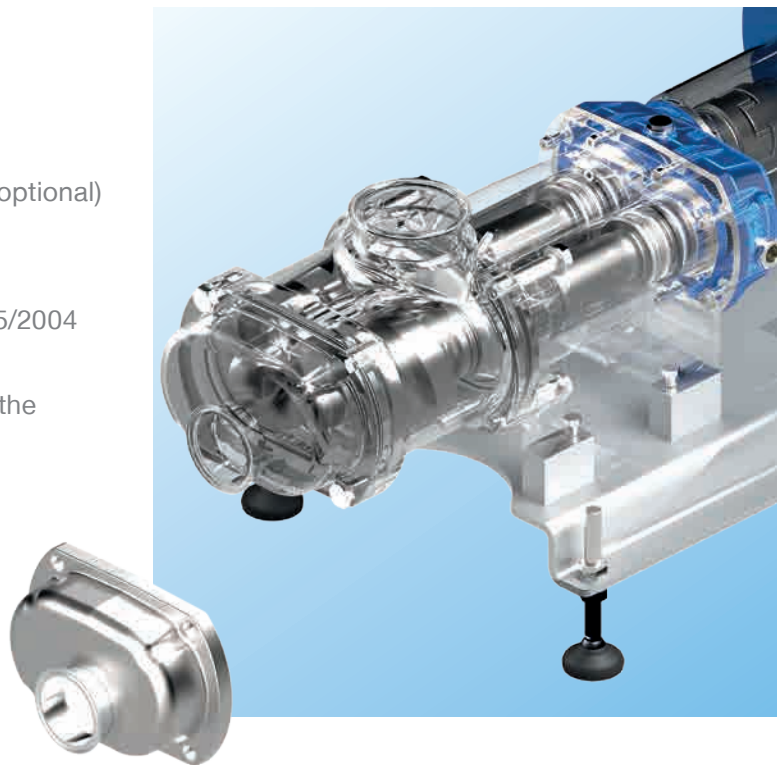

Spare Parts

By using original spare parts from WANGEN PUMPEN, we guarantee that the performance output of our pumps will be fully restored. With our decades of manufacturing competence, you will thus also be able to profit from our first class quality as a manufacturer and as a consequence ensure the long service life of your pump.



Technical Data

Options and Accessories

You will find a wide range of accessories that complement our product range or accessories that can be adapted to suit your individual needs. Thus, you will be able to put together customised solutions. In this case too, we will also gladly advise you, as a number of individual solutions are possible.

- All types of hygienic fittings are available for the WANGEN Twin
- Base plate made of stainless steel 1.4301, optionally with spherical feet (see figure on right)
- Mobile versions with swiveling and fixed castors are available
- Cover over the drive unit (1.4301)
- Surface-hardened feeder screws
- Bearing oil coolers for temperatures up to 150°C
- Heating jacket on the pump casing
- Special designs suitable for adaptation to existing systems possible

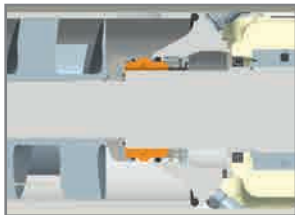
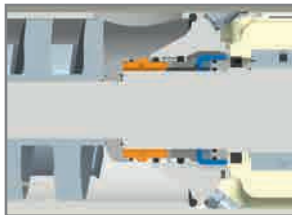

Sealing concepts

| Requirements: | Highest level of hygiene | Aseptic |
|----------------------------|--|--|
| Type of seal: | Single acting mechanical seal | Double acting mechanical seal |
| Material product side: | 2 x silicon carbide or 2 x tungsten carbide | 2 x silicon carbide |
| Material atmospheric side: | none | 1 x carbon 1 x tungsten carbide |
| Location in the pump: |  <p>Mechanical seal on product side</p> |  <p>Mechanical seal on product side. Mechanical seal on atmospheric side</p> |
| Auxiliary seals: | FPM, EPDM, PTFE coated silicon ring | FPM, EPDM, PTFE coated silicone ring |

Characteristics

High suction performance

The axial conveyance and the low acceleration of the product in the pump enables excellent $NPSH_R$ values < 2 m to be achieved.

- For emptying tanks
- With a low suction head to the pump
- For pumping viscous or low-boiling products

Reversible conveying direction

Pumping in both directions is possible by reversing the rotational direction

- For pumping and subsequent emptying of the product line
- Use as a loading and unloading pump

Wide viscosity range

Viscosities up to 1,000,000 mPa.s possible by axial pumping and low amount of kneading work in the product. Good pump output thanks to high rotational speeds also with low viscosities with e.g. 0.5 mPa.s.

- Pumping of all low to high viscosity products
- Pumping of different products using a single pump possible

60% gaseous share possible

The high speeds allow compressible products to be conveyed with the pump.

- For pumping and subsequent emptying of the product line
- Use as a loading and unloading pump

Low pulsation

The axial pumping and low acceleration of product in the pump ensures low pulsation. Any product pulsation that develops could be reduced by increasing the speed of the pump.

- low shear forces maintains the structural and visual integrity of product ingredients
- ensures smooth conveyance of sensitive products
- For applications that require a high dosing precision
- It is possible to extend the pumping distance by installing a series of pumps



Can run dry

The contact-free operation of the feed screws and a flushed / barrier mechanical seal make the pump completely insensible to dry running.

- Pump functions even with a high percentage of gas in the product-line.

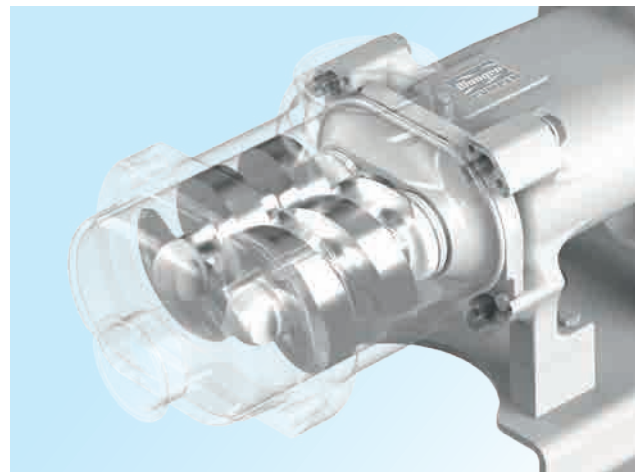

Technical Data

Performance Data WANGEN Twin

| Pump size | Maximum free ball passage (mm) | Max. flowrate (m ³ /h) at viscosity 1 mPa·s | Maximum differential pressure (bar / lbs) |
|-----------|--------------------------------|--|---|
| Twin 70 | 20 | 25 (at 4000 min ⁻¹) | 20 / 290 |
| Twin 104 | 25 | 60 (at 3600 min ⁻¹) | 20 / 290 |
| Twin 130 | 30 | 100 (at 3000 min ⁻¹) | 20 / 290 |

Maximum temperature +130 °C (pumps for higher temperature on request),
viscosity up to 1.000.000 mPa·s.

WANGEN
Twin 70



Version with
grey cast iron housing

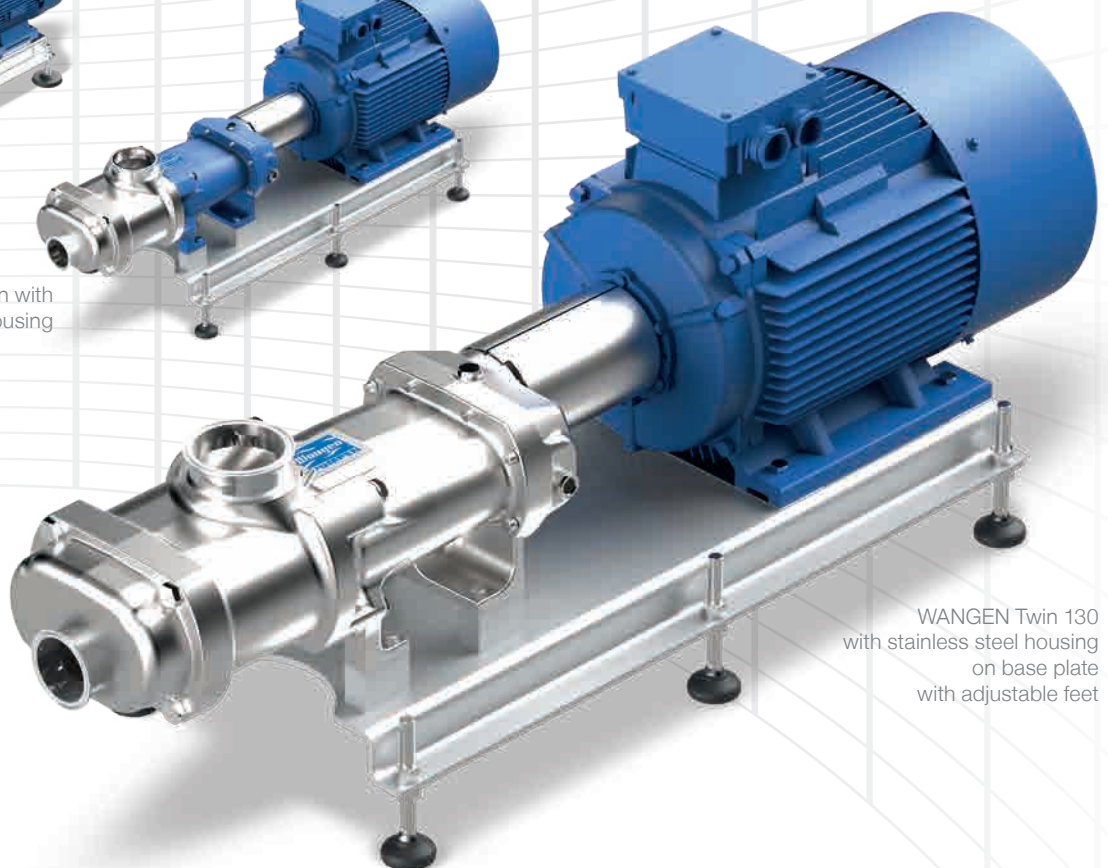
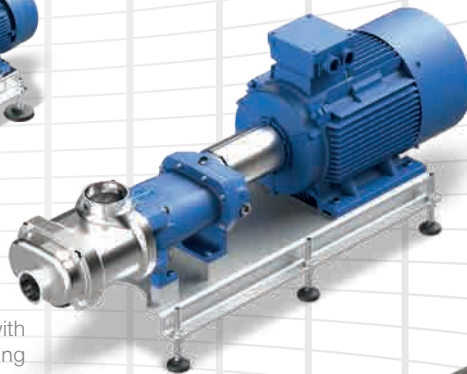

WANGEN Twin 130
with stainless steel housing
on base plate
with adjustable feet

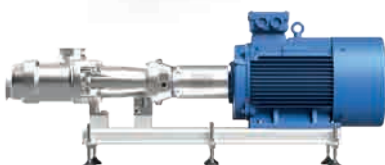



Online Newsletter

Subscribe now and be informed!

Go to www.wangen.com



Tested quality

WANGEN PUMPEN Quality management is certified to ISO 9001:2008.



Certified sustainability

The WANGEN PUMPEN environmental management is certified according to ISO 14001:2004.



Your contact:

Pumpenfabrik Wangen GmbH

Simoniusstrasse 17
88239 Wangen im Allg.
Germany
www.wangen.com

Service Hotline: +49 7522 997-997
Spare parts: +49 7522 997-896