

Hopper feed pump  
**KL-R**

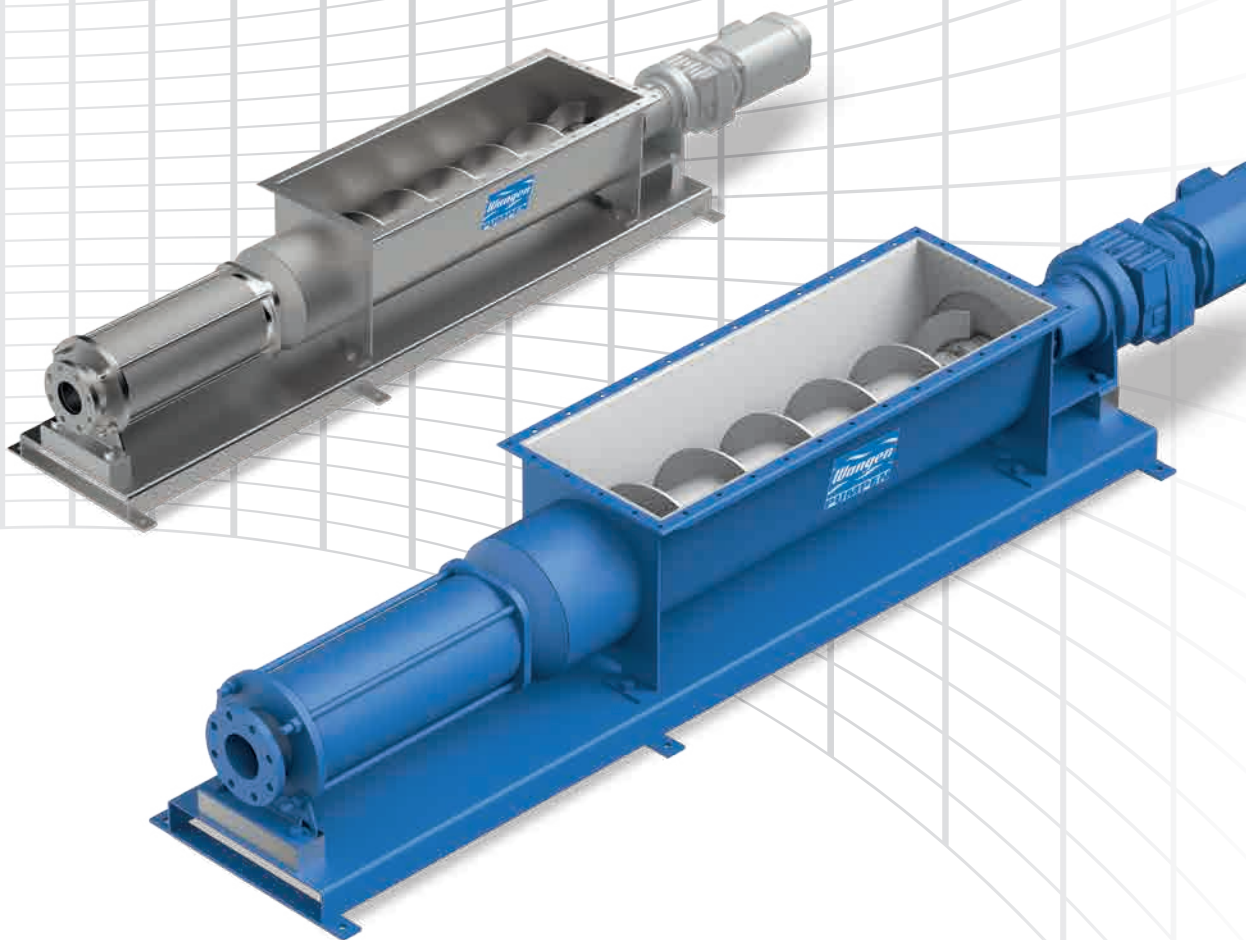

For the gentle conveyance  
of solid and paste-like media

Hopper feed pump

## KL-R

The WANGEN progressing cavity pump of type KL-R and the specially designed hopper housing and modular sealing system enable the gentle conveyance of mediums without influencing the structure or quality of such. The low dead space version of the KL-RL series is ideal for use in the food industry and particularly easy to clean.

The KL-R can handle long distances and great differences in heights, is not sensitive to foreign bodies and also achieves good conveyance performance even with abrasive and fibrous additives in the mediums. A version that can be heated or cooled is available as well and expands the potential use to additional conveyance mediums. It may also be expanded to use an add-on hopper.

Technical highlights:

Flowrate up to 160 m<sup>3</sup>/h,

Temperature up to 140 °C,

Differential pressure up to 48 bar,

Viscosity up to 200,000 mPa·s.

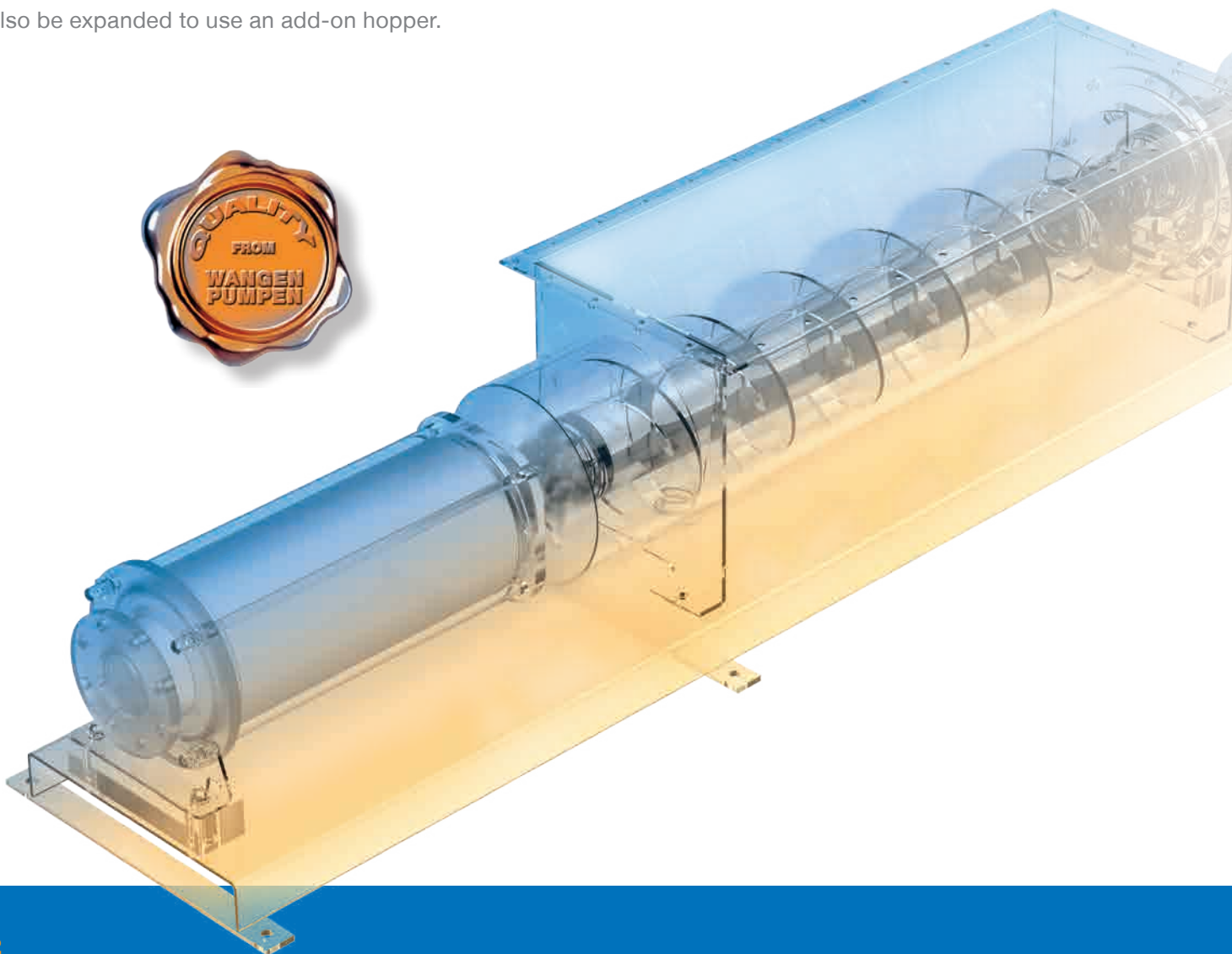

## Applications

# Conveying Materials

The standard version (KL-R) or the hygienic version (KL-RL, designed specifically for the food industry) of the hopper pump can typically be used to convey the following types of mediums:

- Dewatered sewage sludge
- Inorganic sludge
- Food waste, including fish
- Galvanic, iron oxide, coal flotation, gravel wash sludges and gyp mud
- Tar
- Dispersion adhesive, starch glue, PVC adhesive
- Lead paste
- Polishing paste



WANGEN KL-R pumps in operation

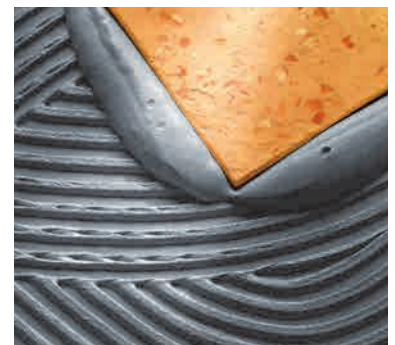

## Benefits

# Low Life-Cycle Costs

When purchase a pump, we recommend that you carefully consider the operating costs as well as the costs for the initial outlay. Maintenance cost, production downtimes and energy costs make up a considerable share of the total costs over the life-cycle of a pump.

In this case, a decisive advantage of our philosophy becomes apparent: in order to keep total costs as low as possible over the entire life-cycle of the pump, our approach is to restrict the frequency of maintenance to a minimum. This can be achieved due to the robust construction of our pumps, the use of high quality wearing parts and choosing a wear-resistant design for each pump.

Every breakdown that can be avoided saves you not only the costs for spare parts, but also the costs for maintenance work and production downtime. In this way, you save money and less stress is caused because of a smooth operation. In this way, you save on your pocketbook and your nerves.

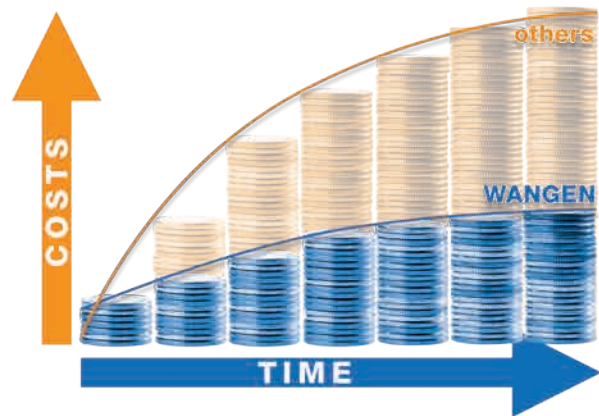

# Easy Maintenance

WANGEN pumps are, generally speaking, particularly usage and maintenance friendly in construction. It is also easy to switch the rotor and the shaft seal due to the accessibility of the connecting bolt and the cartridge construction of the bearing pedestal. This makes it easier for you to carry out the necessary maintenance work yourself.



## Technical Data

# Options and Accessories

You will also find a large range of accessories perfectly coordinated for our product range. This is ideal for enhancing or adapting to your individual requirements. In this way, you are able to receive custom-made solutions. We would be happy to assist you with any special solutions for your needs.

- Temperature and pressure sensors to prevent the pump running dry and the excessive build-up of pressure.
- Pump manufactured in accordance with the ATEX guidelines
- Weighing frame for filling level measurement via weighing cells
- Special versions possible for adaptation to existing systems
- and much more

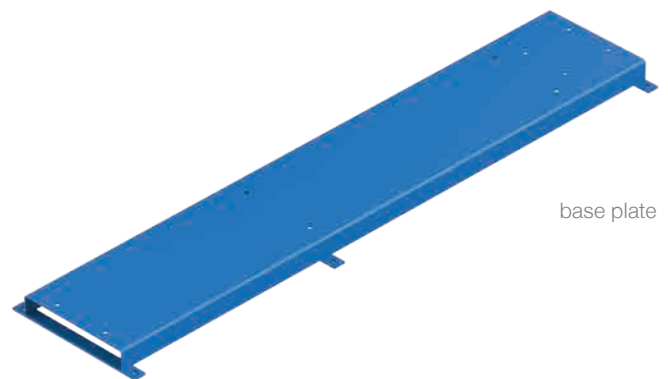

base plate

## Spare Parts

With spare parts from Wangen Pumpen, we guarantee a full service restoration of your pumps. With our many decades of manufacturing experience, we provide you with first class production quality and thus ensure the long life of your pump.



## Technical Data

# Models and Materials

We offer a large selection of accessories, which are perfectly matched to our product range. This provides ideal complement or adaptation to your individual requirements and allows you to create your own customised solutions. We would be happy to assist you with any customized solutions for your needs.

- Hopper housing, pressure flange: grey cast iron, construction steel 1.0038, stainless steel 1.4301, stainless steel 1.4571
- Joint: Cardan joint with screw conveyor in steel or stainless steel
- Seals: mechanical face seals, packing glands, shaft seal
- rings, single and dual acting mechanical seals
- Rotor: hardened tool steel, stainless steel 1.4301, stainless steel 1.4571, both optionally with chrome or chrome-carbide coating
- Stator: diverse NBR materials, FPM, silicone, EPDM, pressure-stable even wall version, solid stators in POM, grey cast iron
- Rotors and stators available in up to 8 pressure classes and S, L and H geometry

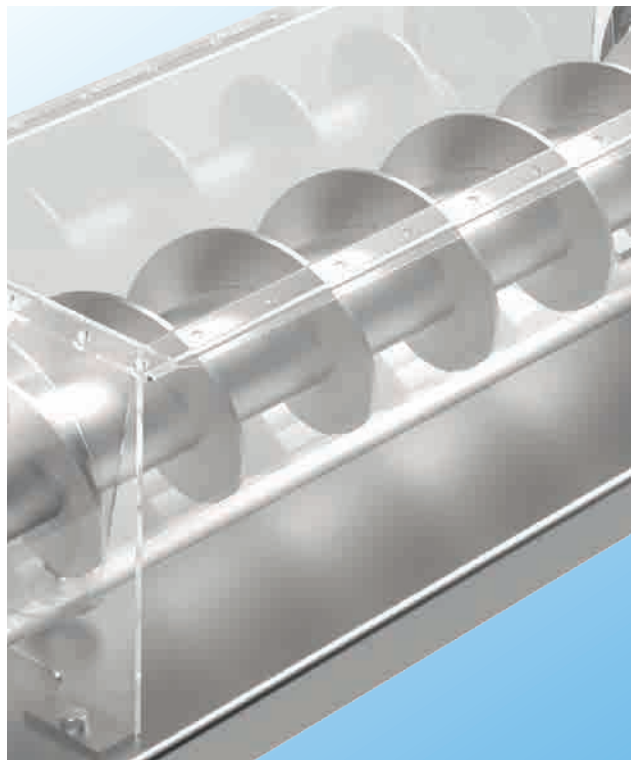

Technical Data

# Performance Data KL-R

Pump size	Maximum free ball passage (mm)	Max. flowrate (m <sup>3</sup> /h) at 350 min <sup>-1</sup>	Maximum differential pressure (bar)
20	24	1,3	48
30	51	6,4	48
50	88	31	48
65	95	44	48
80	121	85	36
100	150	160	48

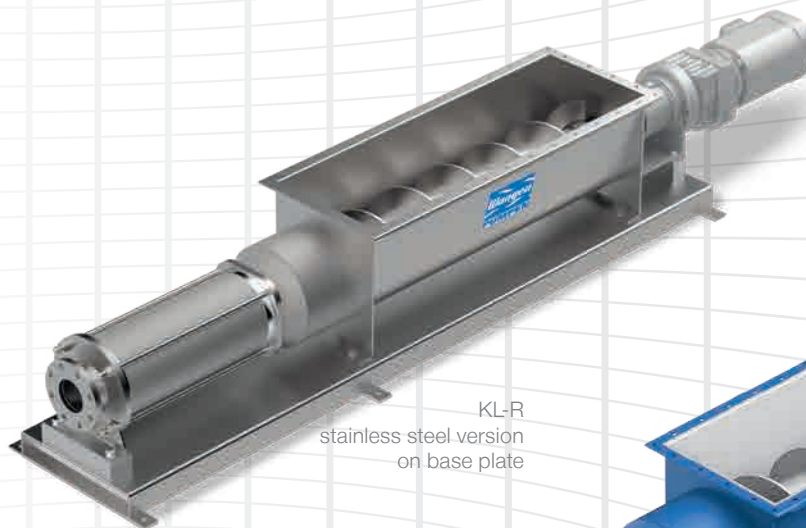

KL-R  
stainless steel version  
on base plate

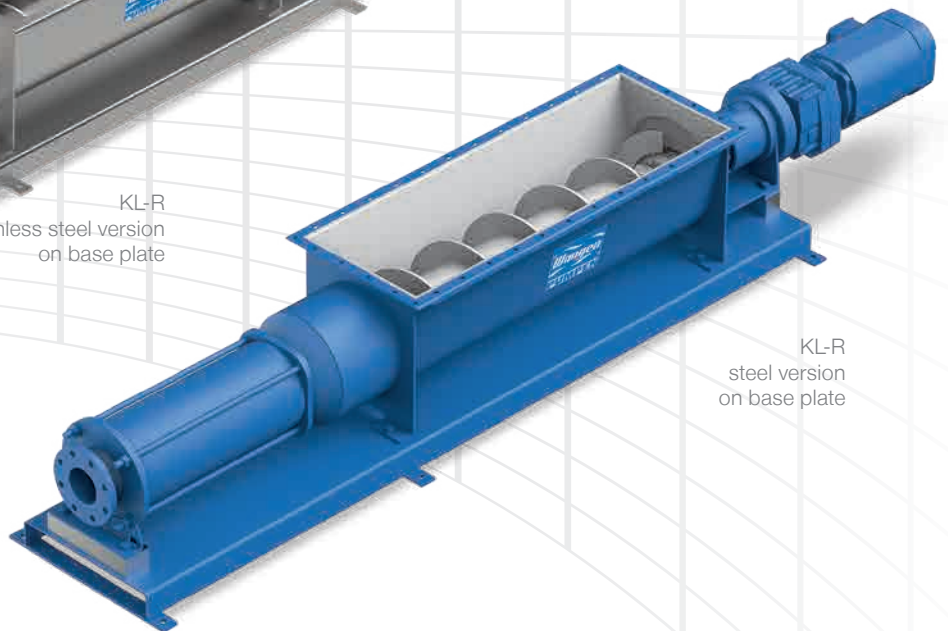

KL-R  
steel version  
on base plate



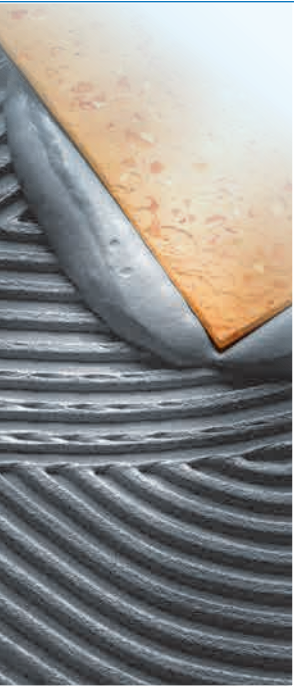

### Online Newsletter

Subscribe now and be informed!

Go to [www.wangen.com](http://www.wangen.com)



### Tested quality

WANGEN PUMPEN Quality management is certified to ISO 9001:2008.



### Certified sustainability

The WANGEN PUMPEN environmental management is certified according to ISO 14001:2004.



Your contact:

### Pumpenfabrik Wangen GmbH

Simoniusstrasse 17  
88239 Wangen im Allg.  
Germany  
[www.wangen.com](http://www.wangen.com)

Service Hotline: +49 7522 997-997  
Spare parts: +49 7522 997-896