

HPL110

specifications

ELECTRICAL

Voltage Range

3 x 110, 220, 240, 380 - 440, 460, 500, 575, 660V ac +/- 10%

Current Range

Internal: max. 8 A. External: N/ 1 or N/ 5 converter

Cosφ Range

0 - 1

Frequency Range

45 - 65 Hz

Consumption

Supply = measuring voltage, 2 VA

Relay Specification

240 VAC/ 5 Amp

MECHANICAL

Housing

Makrolon 8020 (30% GV), UL94V-1 (house)

Makrolon 2800, UL94V-2 (connector + front)

Mounting

Snap-on construction for 35mm DIN rail mounting or panel mounting

Protection Class

IP40 (house). IP20 (connector)

Operating Temperature Range

-15 - +50 °C

Weight & Dimensions

Approx. 400g

D 110 x B 56 x H 75 mm



load monitor with max./min. limit

The HPL110 measures true Power Consumption (kW) calculated by the formula $P = \sqrt{3 \times U \times I \times \text{Cos}\phi}$. In addition to measuring the power and displaying a corresponding value, the HPL110 incorporates programmable minimum and maximum limit settings and an output relay which trips when the limits are exceeded. The HPL110 also incorporates min' and max' reaction delay timers to mask short duration transients, avoiding nuisance tripping, and a delay timer to mask the start up power surge.

Features

- ▲ Measurement of true motor power in kW.
- ▲ Display of kW%, timers and other variables
- ▲ Programmable Min/Max limit settings with alarm relay output
- ▲ Start surge & Reaction delay timers
- ▲ Programmable Hysteresis bands
- ▲ Input for external reset or Auto-reset

Applications

- ▲ Pump dry run and overload protection
- ▲ Protection of screens
- ▲ Protection of macerators
- ▲ Protection of conveyors
- ▲ Protection of cranes and hoists

dimensions

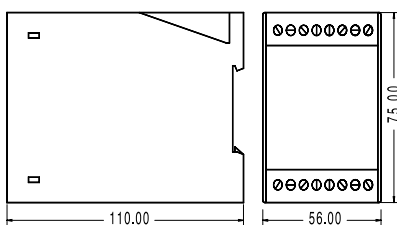

HPL110



function

The Figure to the right shows a typical AC-motor power consumption curve immediately after power has been applied to the motor. The bars at the bottom of the figure indicate power applied to the unit and the position/state of the relay (On/Off). The figure shows the functions and the parameters of the HPL110 in two different situations; hysteresis on the Max. limit and hysteresis on the Min. limit. Note that the use of hysteresis on the Min. limit requires the Max. limit to be Off.

DIP Switches

DIP switches are located under the front plate
SW1 – Tamper Proof. Parameters may be read but not altered when Sw1 is ON
SW2 – Minimum alarm block. When switched ON no minimum alarm will be generated when the kW level $\leq 5\%$ before T_r expires. (used block a Min alarm when motor switched off)

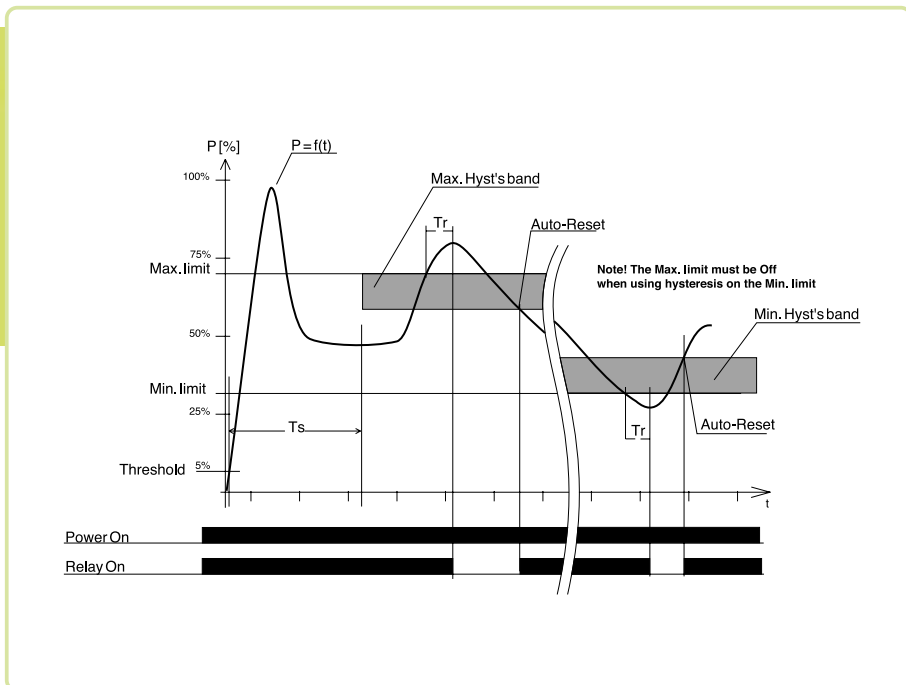

connection

Note: An external current converter (if present) must always be mounted in the L3-phase for correct measurement. The converter polarity is not important.

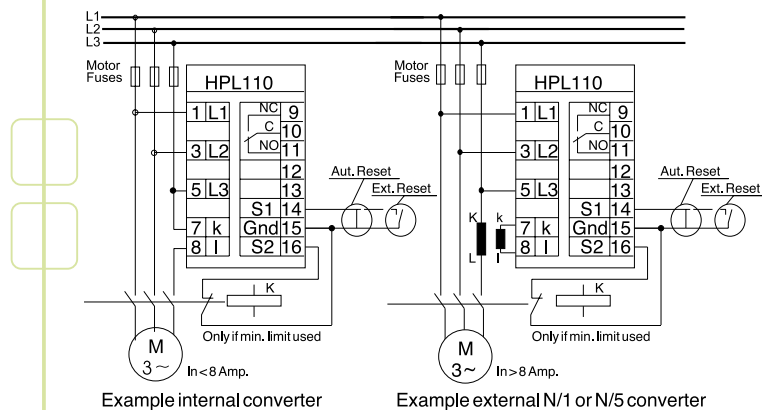

unipower product program

Units for DIN-rail mounting (35mm) or panel mounting (72 x 72).

Measurement transducers: 1- and 3-phase kW-measurement. Symmetric and asymmetric loads. Before and after frequency inverters. Analogue output (4-20mA) as well as pulse output (kWh).

Load monitors: 3-phase symmetric kW-measurement. Programmable kw-limits: Max., Min and dP/dt. Support functions: Start timer, reaction timer, hysteresis, auto reset, manual reset, alarm blocking etc. Analogue output (4-20mA).

Tool supervision: Compact units for supervision of up to 16 cuts. Measurement of power and work for break, wear and missing tool. Monitoring program for installation and statistics, for DOS or Windows.

input

