



Airmove & Airfree Series

KALE FANS

Kale Environmental Technology (Shanghai) Corporation.

✉ liumichael@kalefans.com

🌐 www.kalefans.net

☎ +86 180 1624 5385

📞 +86 180 1624 5385

» Airmove Series

- **Large air volume**

Ultra-long air supply distance, the effective distance of wind speed exceeds 36m, which can cover most of the length of the basketball court;

- **Move freely**

Designed with 4 casters, it can be moved freely to any place where wind is needed indoors or outdoors

- **Energy saving**

The total power of the fan is 0.55kW, the energy consumption is very low, and the energy consumption cost for a whole day of operation is only a few dollars;

- **Quiet and low noise**

The noise is very low, the noise level is 43dBA, when the fan is running, the conversation sound near the fan will not be affected;

- **Stepless speed regulation**

PMSM permanent magnet synchronous motor drives the fan blades, stepless frequency conversion speed regulation, the fan can be controlled freely, the operation is simple and convenient;

- **Water and dust proof**

with IP55 protection grade and overall waterproof performance, the fan can be operated normally in rainy and humid environment; it is easy to clean and while cleaning, do not need to disassemble the frame and directly rinse with water tap;

- **Modular installation**

The overall fan is a modular design, and each module can be installed by the user. If it needs to be transported to other locations, only need to unpack each module, and install it as a whole after arrive at the destination.

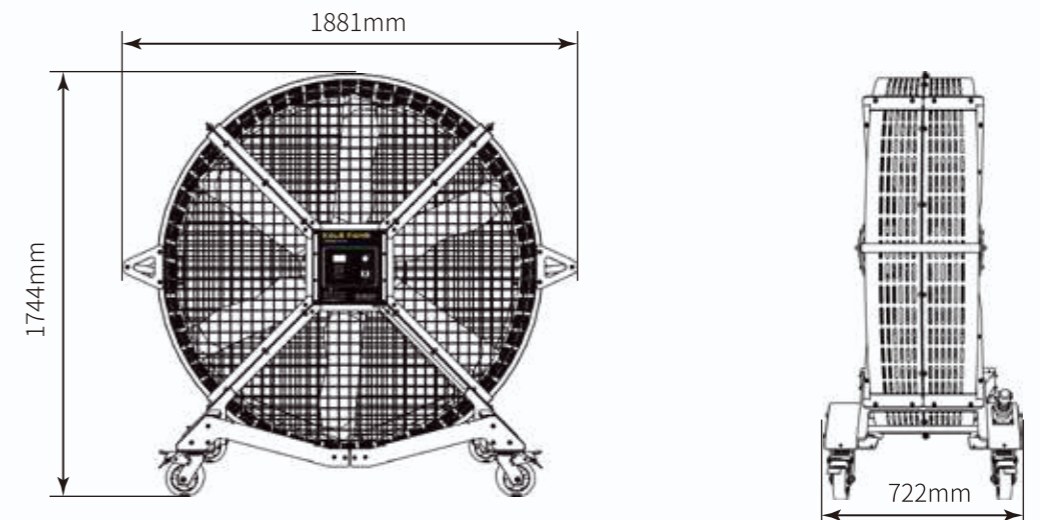
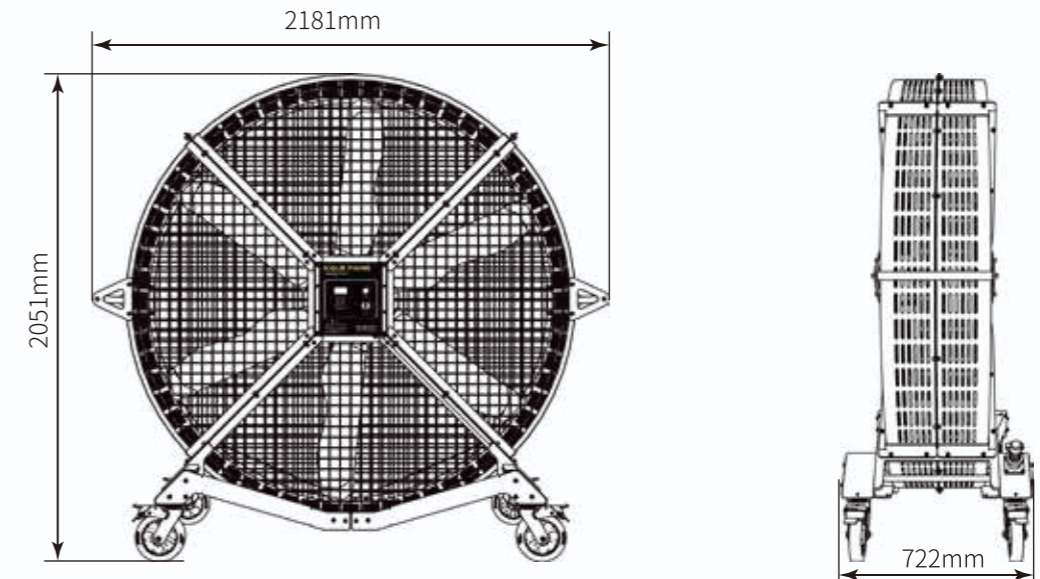

Technical Specifications		
Model	SHVLS-Y6BAA20 (2.0m)	SHVLS-Y6BAA16 (1.6m)
Dimensions(WxHxD)	2181mm x 2051mm x 722mm	1881mm x 1744mm x 722mm
Max speed	320r/min	360r/min
Range of wind speeds	0-36m (wind speeds 7m/s-1.5m/s)	0-24m (wind speeds 7.3m/s-1m/s)
Full load air volume	1208m ³ /min	723m ³ /min
Motor	PMSM Motor	PMSM Motor
Motor Power	0.55kW	0.36kW
Inner Power	220V	220V
Full-load current	2.7A	2A
Sound Level(maximum speed)	43dBA	43dBA
Protection levels	IP55	IP55
weight	176KG	152KG

Application case





Airfree Series

Air supply distance far beyond 36 meters



①

Beam bottom positioning installation

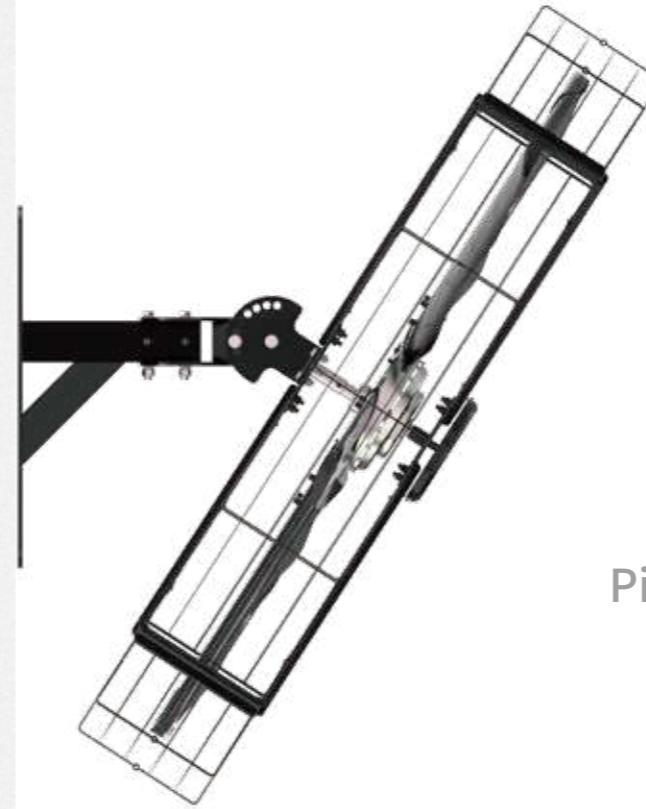

②

Pillar positioning installation

Airfree Series

Product Introduction

Airfree Series is the latest high-volume fan developed by Kale Company; the installation method can be ceiling, wall-mounted, with a total height of 2m, and can be oriented according to the onsite requirements. The fan blades are driven by PMSM permanent magnet synchronous motors to output large and stable air volume ; In the sweltering and irritating environment of the hot summer, Airfree can bring the cooling effect equivalent to more than 20 small fans; the overall steel frame design of the fan is sturdy and durable, and can be applied to most complicated environment places.

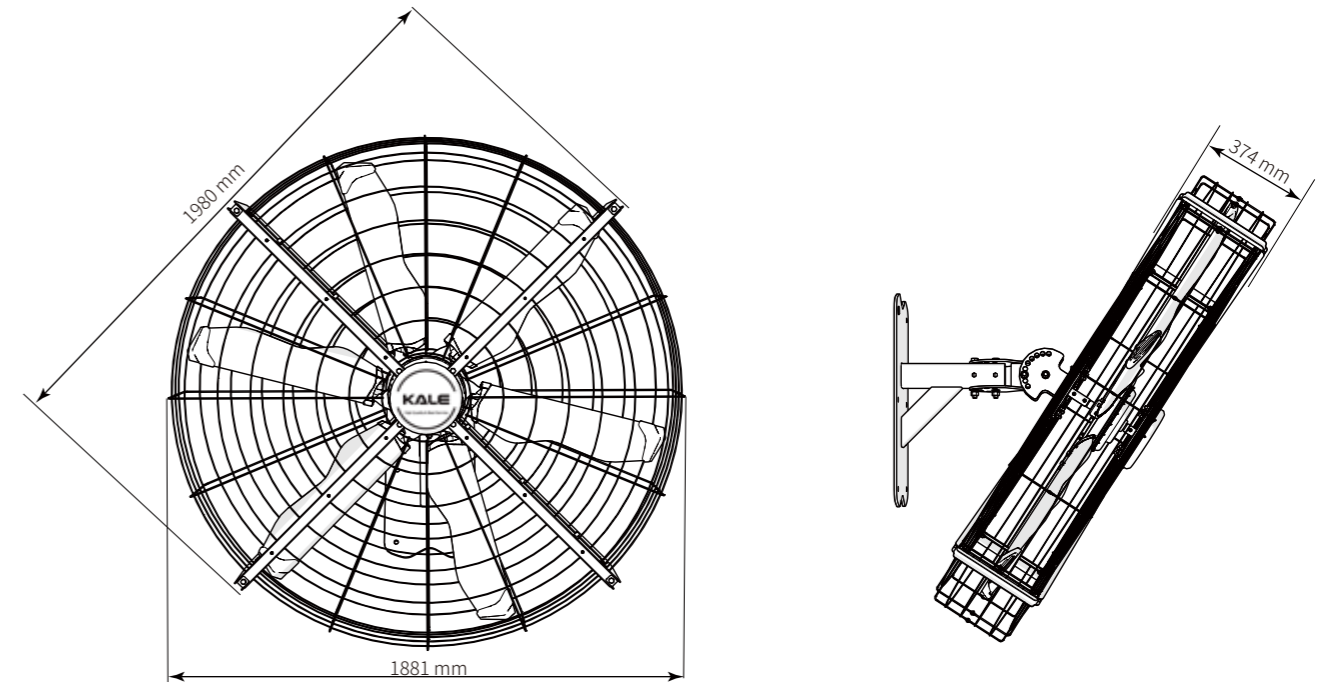

»» Airfree Series

Super air volume

Ultra-long air supply distance, the effective distance of wind speed exceeds 36m, which can cover most of the length of the basketball court;

Directional air supply

There are two installation methods: ceiling and wall mounting, which can supply air according to the requirements of the onsite environment;

Energy saving

The total power of the fan is 0.55kW, the energy consumption is very low, and the energy consumption cost for a whole day of operation is only a few dollars;

Quiet and low noise

The noise is very low, the noise level is 43dBA, when the fan is running, the conversation sound near the fan will not be affected;

Stepless speed regulation

The noise is very low, the noise level is 43dBA, when the fan is running, the conversation sound near the fan will not be affected;

Stepless speed regulation

PMSM permanent magnet synchronous motor drives the fan blades, stepless frequency conversion speed regulation, the fan can be controlled freely, and the operation is simple and convenient;

Water and dust proof

The protection grade is IP55, the whole fan is waterproof, and it can be operated normally in rainy and humid environments ; it is easy to clean;

Technical Specifications

Model	SHVLS-G6BAA20
Dimensions(WxHxD)	1980mm x 1881 mm x 374mm
Max speed	320r/min
Range of wind speeds	0-36m(wind speeds 7m/s-1.5m/s)
Full load air volume	1208m ³ /min
Motor	PMSM Motor
Motor Power	0.55kW
Inner Power	220V
Full-load current	2.7A
Sound Level(maximum speed)	43dBA
Protection levels	IP55
weight	136KG

以籃球場作對比參考/basketball court

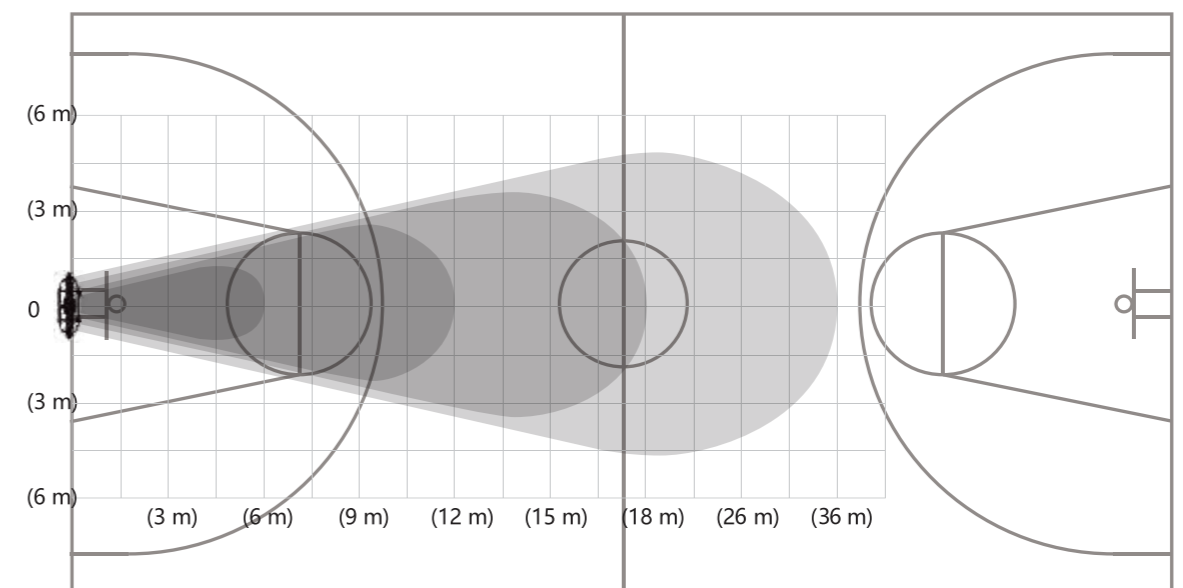

Application case



Manufacturing sophisticated products

Production-advanced equipment

Main production equipment: CNC machining center, PMSM motor winding machine, PMSM assembly line, industrial motor assembly line, forging machine tool, CNC lathe, Chenlong sawing machine, vertical milling machine etc.

Independent research and development equipment: fan controller , power analyzer, dynamometer, simulator etc.



PMSM assembly line



Centralized winding machine



Separation winding machine



CNC machining center



Dust-free assembly workshop

Provide excellent service

Considerate, standard; respect the customer.

Considerate: thoughtful, thorough and meticulous, taking care of all aspects without omissions. Standard: When serving customers, in order to achieve the most efficient and safest goals, there are standard specifications and procedures for each detail process.

With considerate service, standardized service, customer-oriented spirit, serve customers to customers' satisfaction.



China Service Team



India Service Team



Mexico Service Team



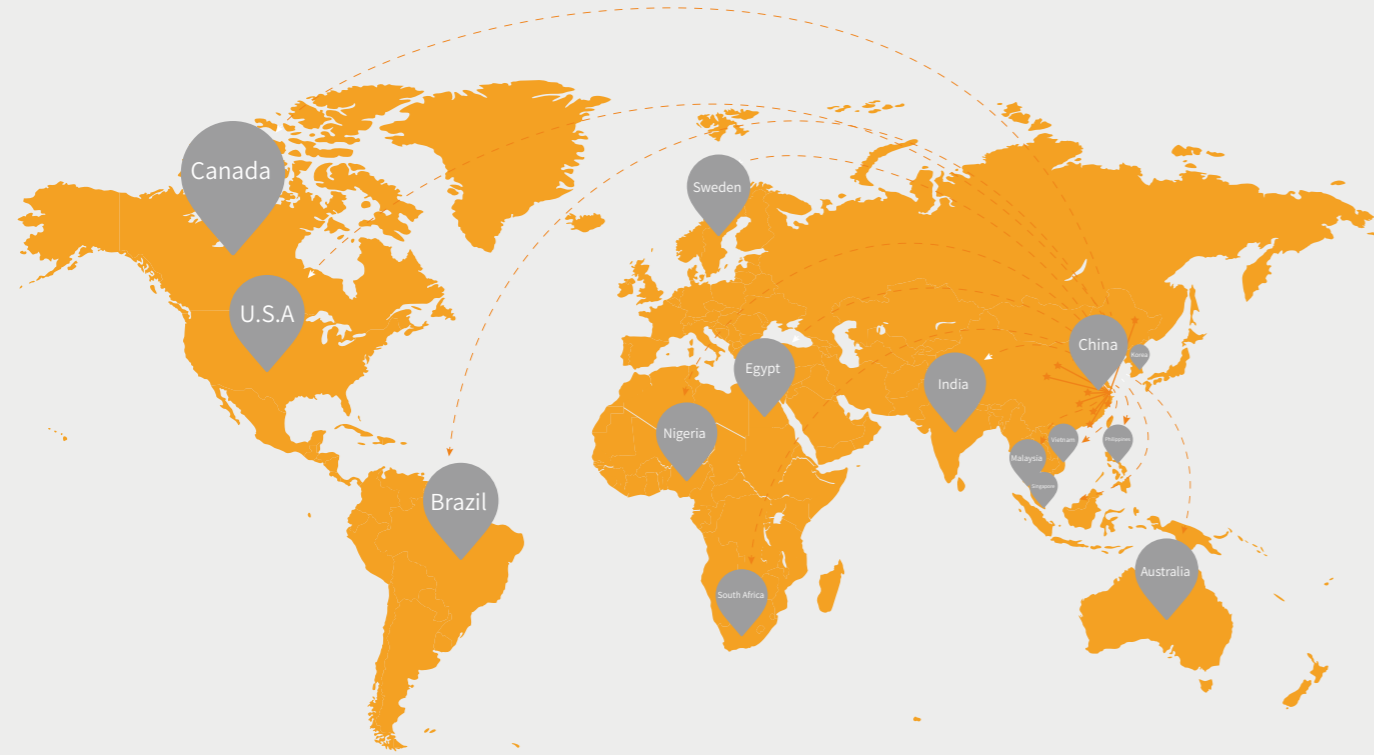

Kale fans are exported to more than 80 countries and regions in Asia, America, Africa, Europe etc.



World sales network

America	Canada	Sweden	Saudi Arabia
Brazil	Australia	South Africa	India
MEXICO	Korea	Malaysia	Singapore

Our customer

Factory&workshop



Vehicle parts



Logistics Supermarket



Public places

